

ON-OFF free flow valves

Series MVMFL - FL UNI PN 10/16

BUROCCO

INDUSTRIAL VALVES srl

Technical data

Size (DN)	DN 8 - 25
Rating	PN 16
Connections	FLANGES DRILLING PN 16
Plug characteristic	Parabolic linear
Action	Manual handwheel
Temperature	-30 to +150 °C

Description

Manual micro-valve angle seat with high coefficient of flow, solid construction and compact. Versatility due to the construction of stainless steel for use in harsh environments.

They can be employed in several sector as: textile dyeing and finishing plants, chemical plants, water-treating, alimentary, general industrial plants.

Options

- ⇒ Special flanges on request (face to face UNI)
- ⇒ Packing box + extension bonnet (for steam max 180 °C)

DN	C _v	K _{vs}
8	2	1,7
10	3	2,5
15	5	4,3
20	9	7,7
25	14	12



ON-OFF free flow valves
Series MVMFL - FL UNI PN 10/16

BUROCCO
INDUSTRIAL VALVES srl

BUROCCO INDUSTRIAL VALVES srl VIA NOVEVIS, 33 - 13867 PRAY (BI) - ITALY

Materials	
Valve body	AISI 316/316L
Flanges	AISI 304/304L (STD)
Insert plug	PTFE (STD) - PTFE/CG
Stem / Plug	AISI 316/316L
Packing	Standard PTFE ring energized with O-ring FPM
Body gasket	PTFE (STD) - PTFE/CG
O-ring	FPM

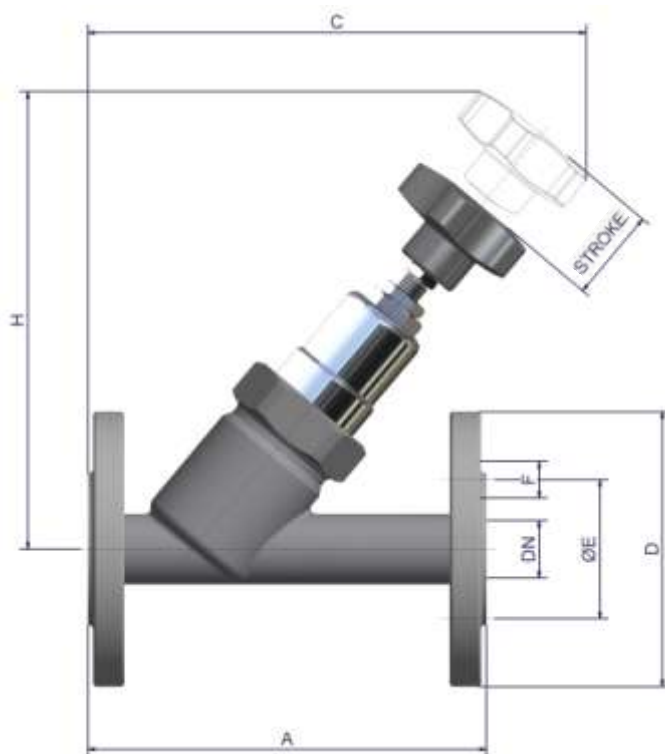

Dimensions (mm)								
DN	A	C	D	E	H	F	n° drills	weight (Kg)
8	130	on request						
10	130	on request						
15	130	160	95	65	155	14	4	2,2
20	150	176	105	75	160	14	4	2,8
25	160	180	115	85	160	14	4	3,3

info@burocco.it — www.burocco.it

Tel.: +39 015 76.72.78 — Fax: +39 015 76.71.36