

# ON-OFF free flow valves Series VMFL - FL UNI PN 10/16

**BUROCCO**  
INDUSTRIAL VALVES srl

## Technical data

Size (DN)	DN 32 - 100
Rating	PN 16
Connections	FLANGES DRILLING PN 16 (32) FLANGES UNI PN 10/16 (40-100)
Plug characteristic	Parabolic linear
Action	Manual handwheel
Temperature	-30 to +150 °C

## Description

Manual valve angle seat with high coefficient of flow, solid construction and compact. Versatility due to the construction of stainless steel for use in harsh environments.

They can be employed in several sector as: textile dyeing and finishing plants, chemical plants, water-treating, alimentary, general industrial plants.

## Options

- ⇒ Special flanges on request ( face to face UNI )
- ⇒ Packing box + extension bonnet ( for steam max 180 °C )

DN	C <sub>v</sub>	K <sub>vs</sub>
32	22	18,8
40	34	29
50	53	45,3
65	91	77,8
80	138	118
100	217	185,5



ON-OFF free flow valves  
Series VMFL - FL UNI PN 10/16

**BUROCCO**  
INDUSTRIAL VALVES srl

BUROCCO INDUSTRIAL VALVES srl VIA NOVEVIS, 33 - 13867 PRAY (BI) - ITALY

info@burocco.it — www.burocco.it

Tel.: +39 015 76.72.78 — Fax: +39 015 76.71.36

Materials	
Valve body	AISI 316/316L
Flanges	AISI 304/304L (STD) AISI 316/316L
Insert plug	PTFE (STD) - PTFE/CG - SILICON
Stem / Plug	AISI 316/316L
Packing	Standard PTFE ring energized with
Body gasket	PTFE (STD) - CARBOFIBER
O-ring	FPM

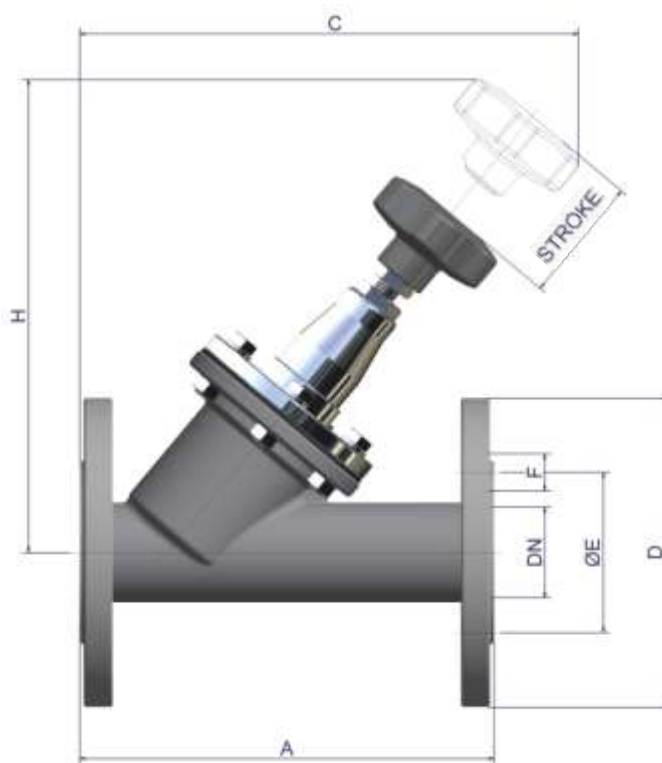

Dimensions (mm)								
DN	A	C	D	E	H	F	n° drills	weight (Kg)
32	180	205	140	100	195	18	4	5,3
40	200	225	150	110	210	18	4	6,8
50	230	240	165	125	220	18	4	10,0
65	290	310	185	145	255	18	4	13,7
80	310	325	200	160	280	18	8	17,5
100	350	355	220	180	295	18	8	23,0